



Frame press – Premium kit

Choose this set when frame straightening is to be performed full time in a dedicated bay.

This straightening set covers the demanding needs to correct a truck chassis. The set can of course be upgraded to increase efficiency and functionality to be able to also straighten (semi-) trailers, cabs and buses.

The set consists of:

- **Three 20 ton press/pull trolleys** with a full set of brackets, all in high strength aluminum. This allows for both press and pull operations to perform side sway correction.
- **Two vertical presses** that together with the anchoring kit enable you to correct vertical bends and chassis twist. Additionally, **a flex foot kit** is included, highly useful when working in a confined space.
- **Three C-clamp kits** (40, 20 and 10 ton) as well as **two hydraulic kits** (20 and 10 ton), which are used to correct local deformations.
- **A remote controlled hydraulic pump** with 4 outlets, as well as a **foot operated pump**, to maneuver multiple hydraulic units at the same time.

For options and accessories, see pages 19–28.

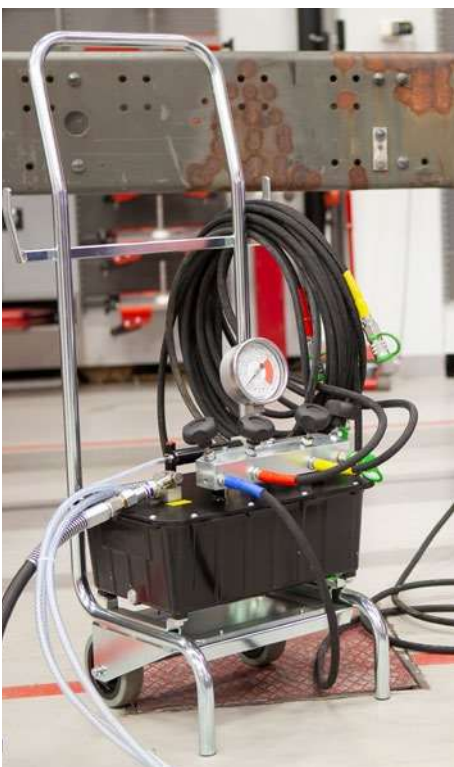



JO FP PREMIUM K/15910

Premium frame straightening kit excluding floor beams

Exklusiv ramriktssats exklusive golvspår

Exklusiv Rahmenrichtsatz exklusive Fundamentrahmen



Premium kit

#	Article #	Order #	Pcs.	EN	SE	DE
1	JO 20 AL	11109	3	Press/pull trolley 20 ton aluminium	Press/dragbrygga 20 ton aluminium	Press/Zugbrücke 20 Tonnen Aluminium
2	JO HA 20	15076	1	20 ton hydraulic kit	20 ton hydraulikillbehörssats	20 Tonnen Zubehörsatz Hydraulik



Table continues on next page
Tabellen fortsätter på nästa sida
Tabelle weiter auf der nächsten Seite

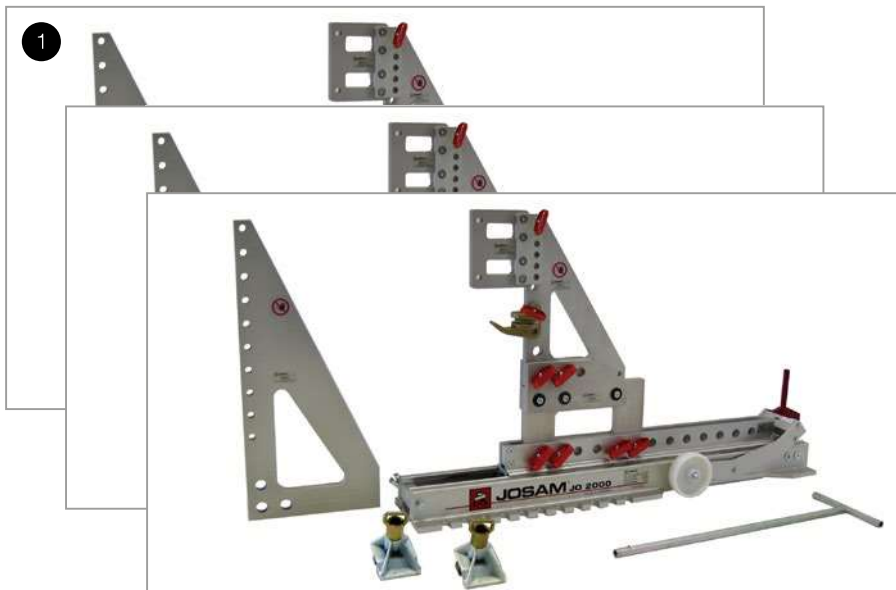

The JOSAM frame press is anchored to a frame rack in the floor.

These rails are not included, but drawings for local construction are provided.

JOSAM frame press förankras i golvspår ingjutna i verkstadsgolvet.

Dessa golvspår ingår ej, men ritningar för lokal konstruktion finns tillgängliga.

Die JOSAM-Rahmenrichtanlage ist an einem Fundamentrahmen im Boden verankert.

Diese Schienen sind nicht enthalten, aber Zeichnungen für den lokalen Aufbau werden zur Verfügung gestellt.



3	JO HA 10	15077	1	10 ton hydraulic kit	10 ton hydraulikillbehörssats	10 Tonnen Zubehörsatz Hydraulik
4	SR 29 K	13495	1	10 ton C-clamp set with flat nose C-clamp	10 ton riktbygelsats med plattnosbygel	10 Tonnen Richtbügelsatz mit Bügel flachen Gegenlager
5	JO 1320 K	12590	1	20 ton C-clamp set	20 ton riktbygelsats	20 Tonnen Richtbügelsatz

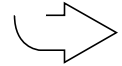

Table continues on next page
 Tabellen fortsätter på nästa sida
 Tabelle weiter auf der nächsten Seite





6	SR 450 N R	12585	1	40 ton C-clamp set for riveting and straightening	40 ton bygelsats för ritning och riktning	40 Tonnen Bügelsatz für Nieten und Richten
7	JO 1876 K	11108	1	20 ton straightening set frame	20 ton riktsets för ramfläns	20 Tonnen Richtsatz Rahmenflansch
8	SR 90 K	12587	1	Mounting display board, three sections	Upphängningstavla, tre sektioner	Montagewand, drei Sektionen

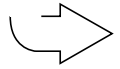
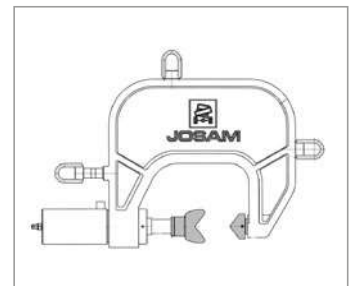

Table continues on next page
 Tabellen fortsätter på nästa sida
 Tabelle weiter auf der nächsten Seite



7



8





9	JO2513	15463	1	20 ton hydraulic cylinder with flex foot	20 ton hydraulisk cylinder med flexfot	20 Tonnen Hydraulikzylinder mit Flexfuss
10	JO2480 A	15818	2	Vertical press 20 ton with cylinder and frame-flange press heads	Vertikalpress 20 ton med cylinder och flänsstöd	Vertikalpresse 20 Tonnen mit Zylinder und Druckstücken
11	JO SA 3	15817	1	Straightening accessories basic set	Riktillbehör grundsats	Richten-Zubehör Grundausrüstung
12	H1039	14953	1	Remote controlled, air driven hydraulic pump with 4 outlets and two 6 m extension hoses	Fjällmanövrerad lufthydraulisk pump med 4 utgångar och två 6-meters förlängningsslangar	Ferngesteuerte, lufthydraulische Pumpe mit 4 Ausgänge und zwei Stück 6 m Schläuche
13	H1053	16544	1	Foot controlled hydraulic pump with two 4 m hoses	Fotdriven hydraulisk pump med två 4-meters slangar	Fußgesteuerte, lufthydraulische Pumpe mit zwei 4 m Schläuche

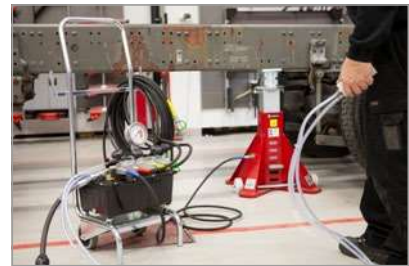
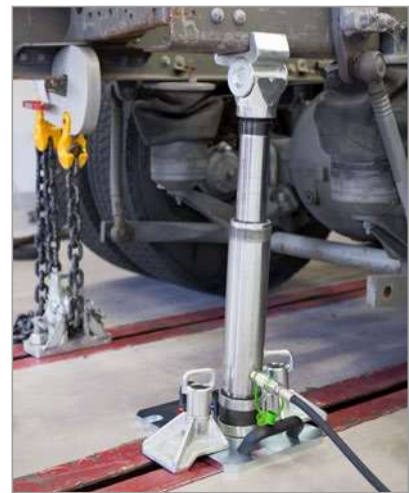



Frame press – Advanced kit

Choose this set when frame straightening is to be performed part time in a dedicated bay.

This straightening set covers the normal needs to correct a truck chassis. The set can of course be upgraded to increase efficiency and functionality to be able to also straighten (semi-) trailers, cabs and buses.

The set consists of:

- **One 20 ton press/pull trolley and two 20 ton counterstay trolleys** with brackets, all in high strength aluminum. This allows for both press and pull operations to perform side sway correction.
- **Two vertical presses** that together with the anchoring kit enable you to correct vertical bends and chassis twist.
- **Two C-clamp kits** (40 and 10 ton) as well as **two hydraulic kits** (20 and 10 ton), which are used to correct local deformations.
- **A remote controlled hydraulic pump** with 4 outlets, to maneuver multiple hydraulic units at the same time.

For options and accessories, see pages 19–28.





JO FP ADVANCED K/15909

Advanced frame straightening kit excluding floor beams

Avancerad ramriktssats exklusive golvspår

Fortgeschritten Rahmenrichtsatz exklusive Fundamentrahmen



Advanced kit

#	Article #	Order #	Pcs.	EN	SE	DE
1	JO 21 AL	11116	2	Counterstay trolley 20 ton aluminium	Mothållsbrygga 20 ton aluminium	Gegenbrücke 20 Tonnen Aluminium
2	JO 20 AL	11109	1	Press/pull trolley 20 ton aluminium	Press/dragbrygga 20 ton aluminium	Press/Zugbrücke 20 Tonnen Aluminium
3	JO HA 20	15076	1	20 ton hydraulic kit	20 ton hydrauliktillbehörsats	20 Tonnen Zubehörsatz Hydraulik

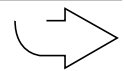
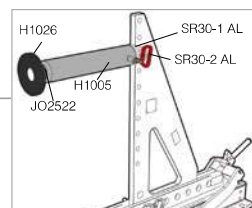

Table continues on next page
Tabellen fortsätter på nästa sida
Tabelle weiter auf der nächsten Seite



The JOSAM frame press is anchored to a frame rack in the floor.

These rails are not included, but drawings for local construction are provided.

JOSAM frame press förankras i golvspår ingjutna i verkstadsgolvet.

Dessa golvspår ingår ej, men ritningar för lokal konstruktion finns tillgängliga.

Die JOSAM-Rahmenrichtanlage ist an einem Fundamentrahmen im Boden verankert.

Diese Schienen sind nicht enthalten, aber Zeichnungen für den lokalen Aufbau werden zur Verfügung gestellt.



4	JO HA 10	15077	1	10 ton hydraulic kit	10 ton hydraulikillbehörssats	10 Tonnen Zubehörsatz Hydraulik
5	SR 31 K	12588	1	10 ton C-clamp set	10 ton riktbygelsats	10 Tonnen Richtbügelsatz
6	SR 450 N R	12585	1	40 ton C-clamp set for riveting and straightening	40 ton bygelsats för nitning och riktning	40 Tonnen Bügelsatz für Nieten und Richten

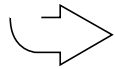
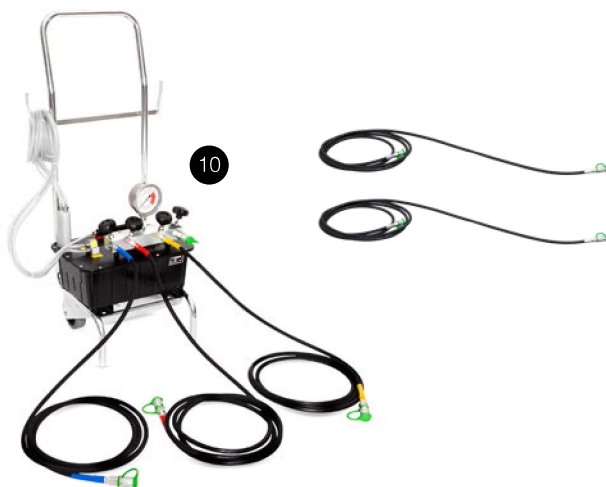
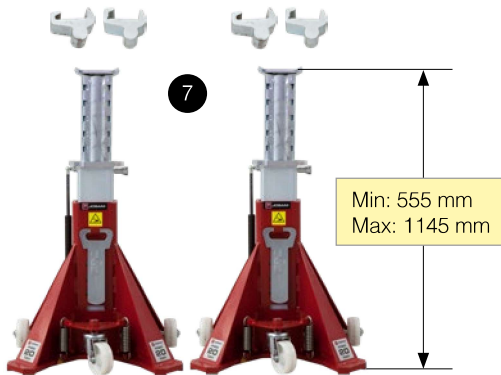

Table continues on next page
 Tabellen fortsätter på nästa sida
 Tabelle weiter auf der nächsten Seite





7	JO2480 A	15818	2	Vertical press 20 ton with cylinder and frame-flange press heads	Vertikalpress 20 ton med cylinder och flänsstöd	Vertikalpresse 20 Tonnen mit Zylinder und Druckstücken
8	JO SA 3	15817	1	Straightening accessories basic set	Riktillbehör grundsats	Richten-Zubehör Grundausrüstung
9	SR 90 K	12587	1	Mounting display board, three sections	Upphängningstavla, tre sektioner	Montagewand, drei Sektionen
10	H1039	14953	1	Remote controlled, air driven hydraulic pump with 4 outlets and two 6 m extension hoses	Fjärrmanövrerad lufthydraulisk pump med 4 utgångar och två 6-meters förlängningsslangar	Ferngeregelte, lufthydraulische Pumpe mit 4 Ausgänge und zwei Stück 6 m Schläuche





Frame press – Basic kit

Choose this set when frame straightening is to be performed part time in an all-round bay.

This straightening set covers the basic needs to correct a truck chassis. The set can of course be upgraded to increase efficiency and functionality to be able to also straighten trailers, cabs and buses.

The set consists of:

- **Three 20 ton counterstay trolleys** with standard brackets, all in high strength aluminum, used together with a **20-ton hydraulic kit** to perform side sway correction.
- **Two vertical presses** that together with the anchoring kit enable you to correct vertical bends and chassis twist.
- **Two C-clamp kits** (20 and 10 ton) as well as **two hydraulic kits** (20 and 10 ton), which are used to correct local deformations.
- **Two foot controlled hydraulic pumps**, to maneuver multiple hydraulic units at the same time.

For options and accessories, see pages 19–28.





JO FP BASIC K/15908

Basic frame straightening kit excluding floor beams

Enklare ramriktssats exklusive golvspår

Einfachere Rahmenrichtsatz exklusive Fundamentrahmen



Basic kit

#	Article #	Order #	Pcs.	EN	SE	DE
1	JO 21 AL	11116	3	Counterstay trolley 20 ton aluminium	Mothållsbrygga 20 ton aluminium	Gegenbrücke 20 Tonnen Aluminium
2	JO HA 20	15076	1	20 ton hydraulic kit	20 ton hydraulikillbehörssats	20 Tonnen Zubehörsatz Hydraulik



Table continues on next page
Tabellen fortsätter på nästa sida
Tabelle weiter auf der nächsten Seite

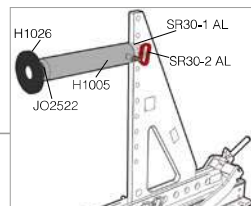
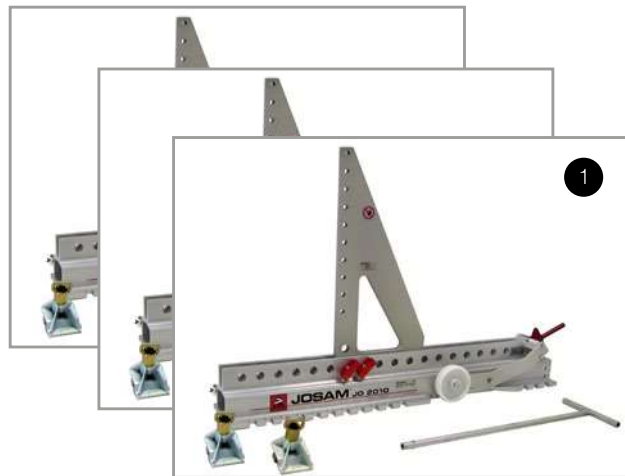

The JOSAM frame press is anchored to a frame rack in the floor.

These rails are not included, but drawings for local construction are provided.

JOSAM frame press förankras i golvspår ingjutna i verkstadsgolvet.

Dessa golvspår ingår ej, men ritningar för lokal konstruktion finns tillgängliga.

Die JOSAM-Rahmenrichtanlage ist an einem Fundamentrahmen im Boden verankert. Diese Schienen sind nicht enthalten, aber Zeichnungen für den lokalen Aufbau werden zur Verfügung gestellt.



3	JO HA 10	15077	1	10 ton hydraulic kit	10 ton hydraulikillbehörssats	10 Tonnen Zubehörsatz Hydraulik
4	JO 1320 K	12590	1	20 ton C-clamp set	20 ton riktbygelsats	20 Tonnen Richtbügelsatz
5	SR 31 K	12588	1	10 ton C-clamp set	10 ton riktbygelsats	10 Tonnen Richtbügelsatz

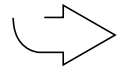
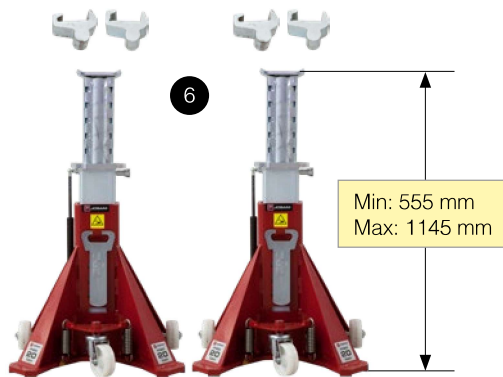

Table continues on next page
 Tabellen fortsätter på nästa sida
 Tabelle weiter auf der nächsten Seite





6	JO2480 A	15818	2	Vertical press 20 ton with cylinder and frame-flange press heads	Vertikalpress 20 ton med cylinder och flänsstöd	Vertikalpresse 20 Tonnen mit Zylinder und Druckstücken
7	JO SA 3	15817	1	Straightening accessories basic set	Riktillbehör grundsats	Richten-Zubehör Grundausrüstung
8	SR 90 K	12587	1	Mounting display board, three sections	Upphängningstavla, tre sektioner	Montagewand, drei Sektionen
9	H1053	16544	2	Foot controlled hydraulic pump with two 4 m hoses	Fotdriven hydraulisk pump med två 4-meters slangar	Fußgeregelt, lufthydraulische Pumpe mit zwei 4 m Schläuche





JOSAM frame press – options

For frame straightening it is highly recommended to use heat to release strain and tension in the frame components. The best tool for this is the JOSAM induction heater, allowing you to concentrate the heat into the required area instead of a gas flame heating a big area.

To increase your efficiency and flexibility, a set of trailer tools, a high reach pulling tower and a storage solution can be added.

For documentation of the frame errors as well as guide during straightening, a laser based frame measuring kit is available. This can be upgraded to a camera based wheel alignment system to make a perfect job by aligning the wheels and axles before the truck is returned to the customer.





JO TRAILER K/15913 Straightening set for trailers Riktsats för trailers Richtsatz für Auflieger



#	Article #	Order #	Pcs.	EN	SE	DE
1	JO 2130 K	11117	1	Frame hook set for semitrailers	Ramhakesats för semitrailer	Rahmenhakensatz für Sattelauflieger
2	JO248003-2	11618	1	Extension tube	Förlängningstüb	Verlängerungsteil
3	JO2475	11610	2	Adjustable frame flange press head for trailers	Justerbart flänsstöd för trailers	Druckstück für Rahmenflanken, justierbar für Auflieger
4	JO 2030 K	11115	1	Frame hook set for i-beam	Ramhakesats för i-balk	Rahmenhakensatz für I-Strebe

